

# Operation Manual Series W-600

W-616



W-630



W-650



W-690



**Table of content**

1	Safety information.....	3	6.7	Language.....	10
1.1	Place of application of the unit .....	3	6.8	Advanced .....	10
1.2	Instructions for installation .....	4	6.9	Power-on option.....	10
2	Start-up and adjustment of controller	5	6.10	Sensoroffset.....	10
3	General information .....	5	6.11	Stop after error .....	10
4	Control panel.....	6	6.12	Heater check .....	11
4.1	Overview of functions .....	6	6.13	Password protection.....	11
4.2	Standard display information.....	6	6.14	Factory defaults .....	11
4.3	Status LED.....	6	6.15	Systeminfo .....	11
4.4	Fault detection .....	7	7	Controller On / Off.....	11
5	Set-up menu .....	8	8	Troubleshooting.....	12
5.1	Adjustment of set-point .....	8	9	Terminal connections .....	13
6	Settings menu.....	8	10	Connector pin assignment.....	15
6.1	Structure of menu .....	9	11	Repair and maintenance.....	16
6.2	Setpoint .....	9	12	Disassembly and disposal .....	16
6.3	Lower / Upper limits.....	9	13	Drilling template .....	17
6.4	Range.....	9	14	EU-Declaration of conformity.....	18
6.5	Type of sensor .....	9			
6.6	Unit .....	10			

## 1 Safety information



Before putting the unit into operation, the safety information, the instructions for installation and the operating manual that is supplied with the unit must be read and observed.

Please read the safety information carefully and comply with the items stated. This is a matter of safety for personnel and equipment. The unit is predominantly designed as a temperature controller for electrical heating systems. Improper application, installation, configuration or operation of a system or that which goes against the machine's intended purpose may cause severe personal injuries and extensive property damage!



**Important: This unit is not a safety temperature limiter according to DIN EN 60730-1**

The unit must not be installed in potentially explosive atmospheres. If a process function originating from an explosion-risk area is to be processed by the unit installed outside the explosion-risk area, all supply lines of the unit leading into the explosion-risk area must be guided via safety barriers!

The prerequisite for error-free and safe operation of the unit is its careful transport and storage, as well as correct assembly and installation. This device may only be installed, configured, parameterized and commissioned by qualified persons who are familiar with installation, commissioning and maintenance of comparable devices and with the system in which the device will be applied and who have appropriate knowledge in the field of instrumentation and control. Operating staff of the system in which the device is to be used must be instructed on operation and control of the unit by qualified persons.

Please observe and comply with:

- The contents of the present manual for installation and operation of the unit, in particular the information on installation, taking into operation, any notes in bold print and adjustment of the device to suit the overall system.
- Any and all safety information attached to the unit.
- Any and all relevant safety regulations for installation and operation of electrical systems
- The keeping of this manual in a safe place for future use.

The regulations stated in the present manual are applicable and valid in all EU countries. For use of the device outside of an EU country, the relevant national rules and regulations must be considered.

This device has been produced and tested in accordance with DIN EN 61010 Part 1 "Safety requirements for electrical equipment for measurement" and has left our company in an error-free condition in terms of its safety and functionality.

### 1.1 Place of application of the unit

The unit is designed as a temperature controller for flexible application in electrical heating systems. The place of operation or installation of the temperature controller must not be close to motors,

transformers, circuit breakers or other inductive loads, it must be shock-free and vibration-free and positioned on solid ground. The ambient temperature at the place of installation must be between  $-20\text{ }^{\circ}\text{C}$  and  $50\text{ }^{\circ}\text{C}$ , with a relative humidity of  $< 90\%$  (noncondensing). Aggressive and corrosive gases and vapors may damage the unit.

## 1.2 Instructions for installation

Please read the installation instructions carefully and comply with all conditions mentioned here during installation of the unit. In case of non-compliance with the Instructions for installation, faults or malfunctions may occur or the unit may fail to comply with the required EMC guidelines and the conditions for CE-conformity will not be fulfilled.

Before connection of the unit and before putting it into operation, please ensure that the operating voltage and the conditions for the operating voltage required by the unit correspond to the conditions on site (cf. name plate). If required, take any appropriate measures.

Please make sure that the control and load voltage on site are switched off and secured against accidental reactivation during installation of the device. The electrical connections must be made on the basis of the connection diagram and the relevant national rules and regulations. The supply lines for the device must be laid such that they are free from any tensile loads and are not exposed to risks of shearing or crushing under any circumstances.

The mains connection and the connections for the loads must each be provided by suitable cables with a suitable cross-section for the heater.

For sensor lines and signal lines, it is highly recommended to use shielded cables (especially if lines are long and/or running along potential sources of interference); for thermocouples, shielded compensation lines should be used likewise. Sensor lines and signal lines must be installed such that they are spatially separated from the load and control lines (high-voltage lines). If signs of incorrect switching behavior are detected the circuit must be put out of service until remedial action.

For intermediate clamping of compensation lines for thermocouples, no regular terminals may be used, since this would result in generation of additional thermocouples that may falsify the measuring results.

Connect the shield of the sensor lines and the signal lines with the signal ground within or as close to the unit as possible and lay a line with a suitable diameter (same as line to heater) from this point to the PE bus bar along the shortest possible route.

Any inductive loads activated by the unit, such as contactors, valves, motors, transformers, etc. must be wired separately and interferences must be prevented using device-specific suppression devices.

The heater circuit must be protected with a suitable circuit breaker. See Chapter 9, page 13

The present manual does not contain all notes for regulations, standards, etc. that must be observed and complied with during working with the unit in connection with systems and plants. Any such regulations, standards, etc. shall be complied with and observed by the operator of the unit with regard to specific requirements of the respective system or plant.

## 2 Start-up and adjustment of controller

The unit is delivered with a default setup. This Setup mostly will not fit to the application. The controller has to be set to the application-specific temperature limits and sensor type.

### *Power-on*



***Carefully inspect the wiring and connections once again.***

Incorrect wiring or connection of the unit may cause severe damage of the unit and the plant. Please make sure that during initial switch-on of the unit the load voltage of the plant is switched off since the unit will not yet have been adjusted to the plant and may possibly trigger faults or malfunctions.

Now, switch on the operating voltage of the unit.

### *Setup*

Enter the Setup menu and set the values for lower / upper limit and range. Choose the desired temperature sensor. See also chapter 65 Set-up menu on page 8

## 3 General information

The W-600 is a compact, feature rich, intuitive FAT Temperature Controller for wall-mounting. FAT stands for Fast-Adaptive-Tuning. A novel algorithm permanently adjusts the control parameters to the control process. The common adjustment of PID controllers or the execution of an auto tuning procedure is obsolete.

The self-optimizing controller logic leads to an efficient adaption to any closed-loop controlled pass and quickly reaching adjustment between set-point temperature and actual (temperature) value.

All functions are easily accessible via the text menu display and can be easily reached and set via the buttons on the control panel.

The W-600 is equipped with a wear-free electronic for prolonged lifetime.

A multi-colored LED is signaling the different operating modes, easy viewable in the distance.

The electronics is protected against overcurrent and high thermal load.

## 4 Control panel

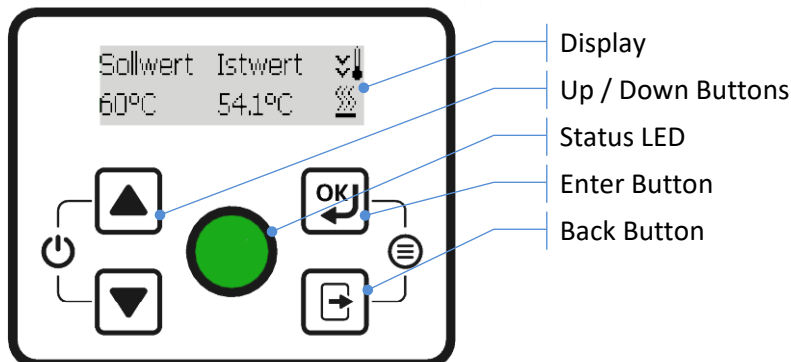

### 4.1 Overview of functions

- Enter set up menu: simultaneous pressing enter button and back button
- Change set-point temperature: Long press up or down button
- Failure receipt: pressing enter button to delete the failure if it has been corrected
- Controller On / Off: simultaneous pressing up button and down button for several seconds

### 4.2 Standard display information

- Set-point temperature: Temperature setting maintained by the controller
- Actual (temperature) value: Actual temperature measured by connected temperature sensor
- Thermometer Icon: Temperature above / beneath / in-between range around the set-point temperature
- Heater-Icon: The icon shows detection of needed power is in progress. This happens during startup or on changed set point temperature.  
During continuous operation a partly filled triangle shows the needed power.

### 4.3 Status LED

#### Starting procedure:



After connecting to power supply, the controller starts with a self-test: white is LED on.  
After Self-test successfully completed, the LED is shortly green and then controller starts heating.  
If a failure is detected an error signal will show up: see 4.4 Fault detection.

**Heat-up phase:**



Usually, after startup, the temperature is below the set point and the signal LED flashes slowly (1 Hz) blue. This means that the heating is active and the set point is not reached yet.

**Set-point temperature reached:**



The Controller works at set-point temperature inside the range set by the user: green LED permanent on

**Temperature monitor:**

The LED remains green at set-point temperature is in-between the range. Above and below this temperature range the LED starts to blink with a frequency of 1 Hz. Blue signals too low and red too high temperatures.

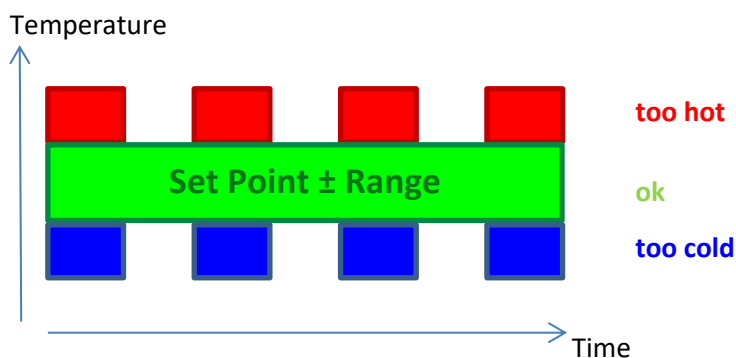

**4.4 Fault detection**

From start and during operation the controller is permanently checking the following failure:

1. PCB temperature
2. power supply
3. sensor break
4. failure of the switch

**Signal LED on failure**

If any failure occurs the controller stops heating (stand-by) and the Signal LED starts fast blinking with a frequency of 4 Hz:

1. Device failure: 4 Hz
2. Sensor failure:



**Display on failure**

Additionally, the error is shown in the display. Failure notes can be reset by pressing enter button . If the failure note cannot be reset by this procedure, the occurring problem has to be solved and the controller reconnected to power supply to restart the controller.

Please also see chapter 8 Troubleshooting on page 12.



## 5 Set-up menu

### 5.1 Adjustment of set-point

To get from normal operation directly to Set Point adjustment, just long-press the button ,  or .

Display:





Pressing Up  or Down  buttons to change value between lower and upper limit. These limits also can be set by the user (see chapter 6.3, page 9).

Enter Button  : Confirms chosen set point temperature

Back Button  : Abort, so setpoint stays unchanged.

## 6 Settings menu

Enter set-up menu by simultaneously pressing Enter Button  and Back Button  . All settings can be adjusted in the menu.

Display:



Pressing Up  or Down  Buttons to navigate through the menu.

To enter a menu item, press the Enter Button .

To leave any menu item, press the Back Button .



**6.1 Structure of menu:**

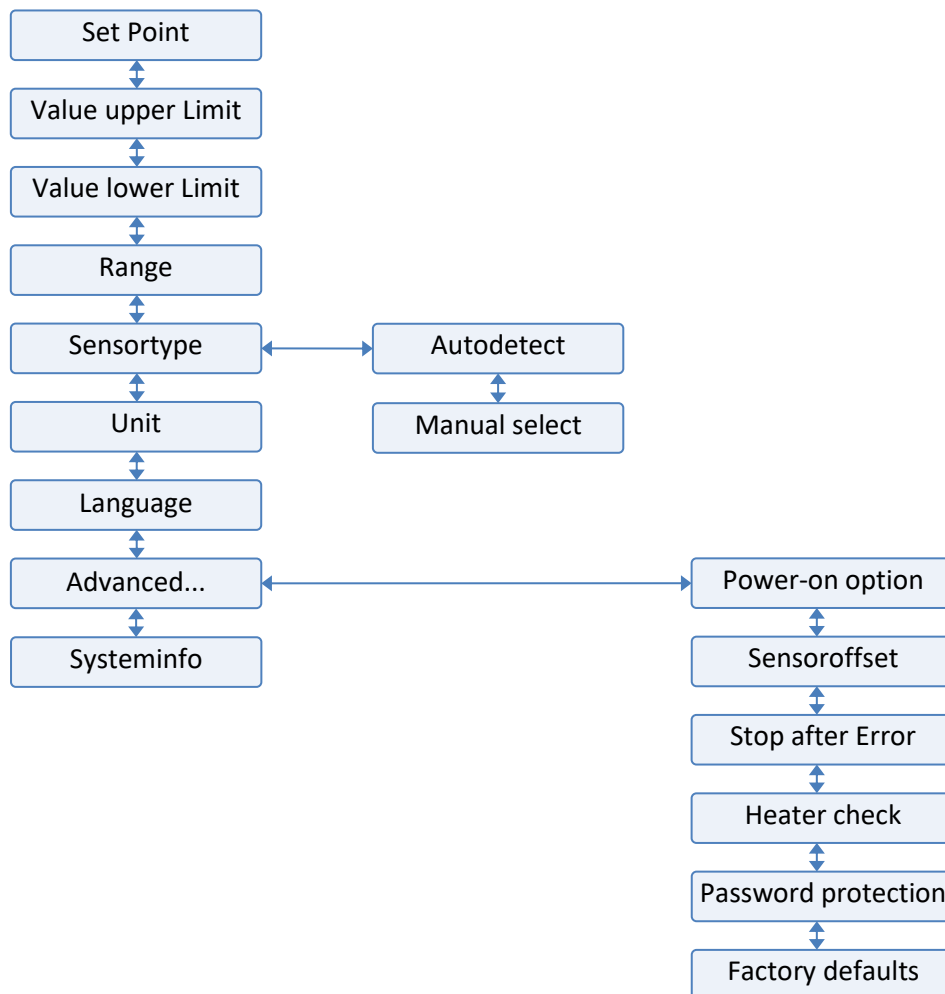

**6.2 Set-point**

See 5.1

**6.3 Lower / Upper limits**

Limits for minimum and maximum temperature values of the set-point adjustment. Adjust these values according to the process environment. This avoids accidentally wrong setting of setpoint values according to used heater. Limits can be adjusted according to selected sensor type.

**6.4 Range**



Current actual temperatures inside the Range are considered balanced to the set-point value, signaled by the green LED-light on and the symbol ✓↓ on the display. Range settings between ±0,5 °C and ±20 °C. Step width is 0.1 °C (factory default: ±3 °C).

**6.5 Type of sensor**

**6.5.1 Auto detection**

The auto detection recognizes the following sensors:

- PT100 (2-, 3- or 4-wires)
- PT1000 (2-, 3- or 4-wires)
- Thermocouple (Type K)

The Auto detection can be started by pressing enter  inside the sensor menu.  
The found sensor type has to be confirmed by pressing enter  again.

Back  aborts the process of detection and parameters stay unchanged.



***All other types of sensors have to be chosen manually.***

### 6.5.2 Manual selection of sensor

A List of all sensors will show up. Select desired sensor type out of list and confirm by pressing enter  (factory default: Pt100 2-wire).

## 6.6 Unit

Selection between degree Celsius (factory default) and degree Fahrenheit.

## 6.7 Language

Languages available: German (factory default), English, Spanish, French and Japanese.

Hint: In every language the language menu and the languages are always labeled in English as well.



## 6.8 Advanced

The following options are available on devices with firmware 1.11 or later:

### 6.9 Power-on option

(from firmware version 1.11) This defines the behavior of the controller after connecting to mains supply.

Possible options are:

- Always power on (factory default): Controller starts up every time mains supply gets connected.
- Stay off: Controller stays off after mains supply gets connected. Controller must be switched on manually by pressing the keys  and  simultaneously.
- Last state: Controller changes to the last state before power loss.

### 6.10 Sensoroffset

(from firmware version 1.11) This option adds an additional offset to the current measured temperature. So, for example, wire resistance on Pt100 2-wire sensors can be compensated (factory default: 0.0 °C).

### 6.11 Stop after error

(from firmware version 1.11) If this option is set to “yes” (factory default), the controller remains stopped after each error and shows the error permanently. Heating is deactivated.





If this option is set to “no”, the controller waits till the error condition is solved and automatically continues operation.

### 6.12 Heater check

(from firmware version 1.11) If this option is set to “yes” (factory default), the controller checks if there is a heater present at the heater connection. A minimum of 10 W is required. If no check is desired, because there is a relay or SSR present instead of a heater, please select “no” then no check is performed.

### 6.13 Password protection

(from firmware version 1.11) If this option is set to “yes”, then a 4-digit Password is requested. Enter a 4-digit code. This code will always be requested again, if the user wants to enter the setup menu. Set Point Temperature still can be adjusted from normal mode of operation (see chapter 5.1 on page 8). To prevent user also from setting a new set point, please set upper limit and lower limit to the same value as Set Point (see 6.3,page 9). So the set point cannot be changed from normal mode anymore.

To enter the password, change the current digit with  and . Confirm with . The cursor then switches to the next digit. If all digits are set, the password is completely displayed and must be confirmed again with . Please remember the password well or note it down on a secure place. The process can be cancelled anytime with . The previous settings remain active.

Should the password get lost, please contact our service at [service@winkler.eu](mailto:service@winkler.eu)

Please note: For your own safety, the request for the factory-reset-password will be recorded at our service. We will only provide the factory-reset-password after receiving your full name, email and phone number.

### 6.14 Factory defaults

(from firmware version 1.11)



If “yes” is selected, and confirmed with , all settings get lost!



This can be used, to set the controller to factory defaults to begin with a fresh configuration.

### 6.15 Systeminfo





Information about the product: firmware and hardware version

## 7 Controller On / Off

The controller switches automatically on with the power supply connected.

By simultaneously long pressing  and  the controller goes to standby or can be powered on again.

## 8 Troubleshooting

Error:	Actions:
<b>Display stays off</b>	<ul style="list-style-type: none"> <li>• Check power supply</li> <li>• press  and  together for a few seconds to power on.</li> <li>• Disconnect and reconnect controller from mains supply.</li> <li>• Contact Service.</li> </ul>
<b>Message „sensor failure“</b>	<ul style="list-style-type: none"> <li>• Press  and  together to enter menu and check sensor settings (correct sensor type selected?).</li> <li>• Check wiring for short circuit or wire breaks, check connection in Terminal / Plug.</li> <li>• Check resistance value of Sensor.</li> <li>• Replace Sensor.</li> </ul>
<b>Message „controller overheated!“</b>	<ul style="list-style-type: none"> <li>• Press  to acknowledge error or disconnect controller from mains supply and let cool down. Then reconnect.</li> <li>• Check correct connection in terminals for mains supply and heater connection.</li> <li>• Provide better air circulation.</li> <li>• Check current in Heater circuit.</li> </ul>
<b>Message „AC line error!“</b>	<ul style="list-style-type: none"> <li>• Disconnect and reconnect controller from mains supply.</li> <li>• Are stable 50 Hz or 60 Hz available?</li> <li>• Power off sources of noise on mains supply like big motors or power converters.</li> <li>• Install suitable noise suppression measures.</li> <li>• Used on mobile power generator? Check voltage and Frequency. Choose suitable supply. Test on local power grid. Message still appears? Contact service.</li> </ul>
<b>Message „system fault“</b>	<ul style="list-style-type: none"> <li>• Disconnect and reconnect controller from mains supply.</li> <li>• Message still appears? Contact service.</li> <li>• Message does not appear? Check all settings and readjust if necessary.</li> </ul>
<b>Message „heater/switch broken!“</b>	<ul style="list-style-type: none"> <li>• Check wiring of heater circuit.</li> <li>• Check heater for short circuit or wire break.</li> <li>• Power of heater too low? Less than 10 W?</li> <li>• Disconnect and reconnect controller from mains supply.</li> <li>• Under Advanced -&gt; Switch off heating circuit monitoring</li> <li>• Message still appears? Contact Service.</li> </ul>
<b>Password lost</b>	<ul style="list-style-type: none"> <li>• See chapter 6.13, page 11</li> </ul>

Service mail: [service@winkler.eu](mailto:service@winkler.eu)

## 9 Terminal connections

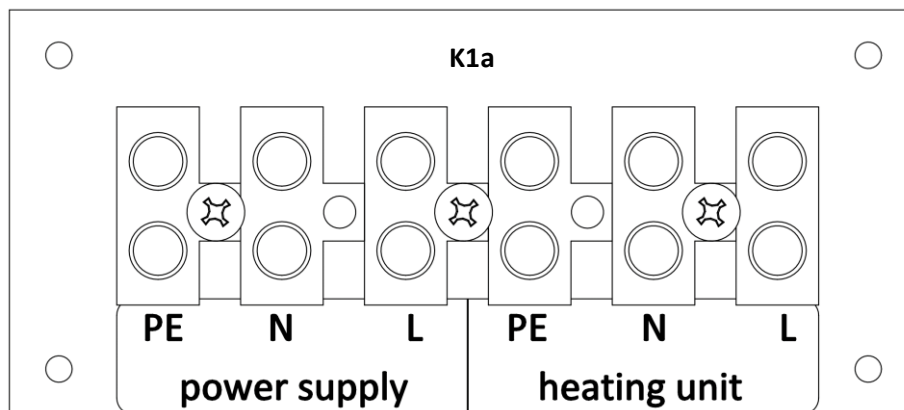
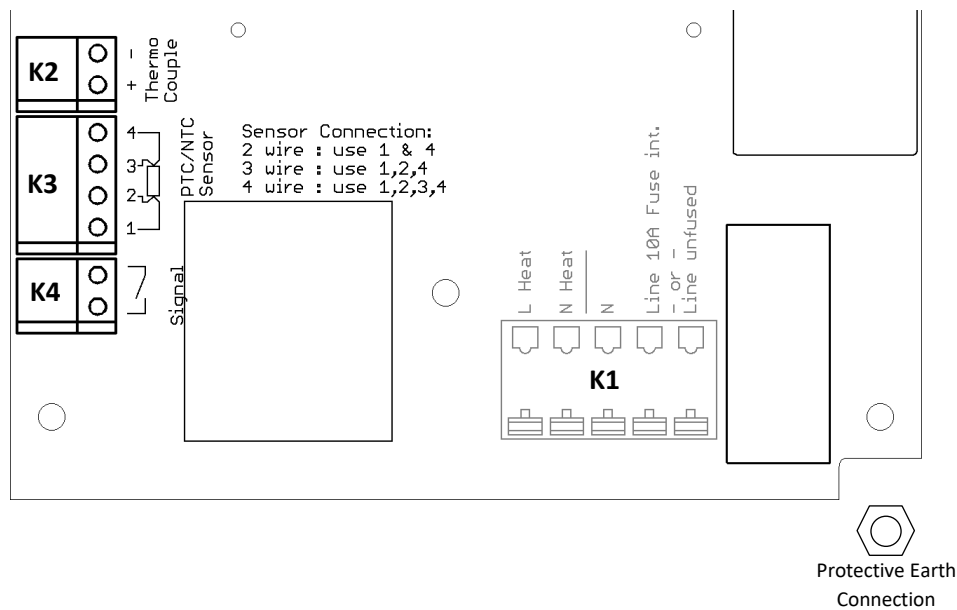

**K1:**



**Do not change the wiring on this terminal! Otherwise the device might be damaged or will malfunction!**

**K1a:** power supply and heating unit, Conductors up to 16 mm<sup>2</sup> or AWG 6

- L: Clamp for phase conductor
- N: Clamp for neutral conductor
- PE: Protective Earth conductor

**K2:** Thermocouples (**Check for correct polarity!**)

**K3:** Resistance temperature sensors (Pt100/1000, Nickel120, NTC10k/100k, etc.)

- 2-wire sensor, clamps K3.1 and K3.4
- 3-wire sensor, clamps K3.1, K3.2 and K3.4
- 4-wire sensor, clamps K3.1, K3.2, K3.3 and K3.4

Wiring-Scheme for K3:



**K4:** Potential-free signal for external monitoring or control systems

### 10 Connector pin assignment

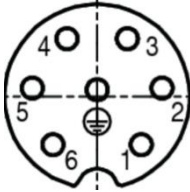
W-630 - Standard plug arrangement		Connector drawing  Heater (max. 10 A) must be protected with external fuse
1	L Heater	
2	N Heater	
3	(w)* Sensor RTD (4 wire only)	
4	(r)* Sensor RTD (3/4 wire only)	
5	(r)* Sensor RTD; Sensor TC +	
6	(w)* Sensor RTD; Sensor TC -	
PE	Protective earth connection	

\*(IEC 60751)

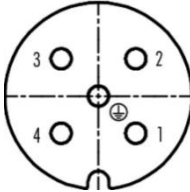

W-650 - Standard plug arrangement		Connector drawing  Heater (max. 20 A) must be protected with external fuse
1	L Heater	
2	N Heater	
3	Sensor RTD; Sensor TC +	
4	Sensor RTD; Sensor TC -	
PE	Protective earth connection	

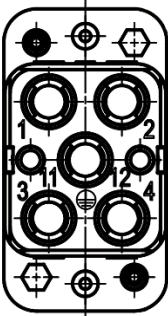
W-690 - Standard plug arrangement		Connector drawing  Heater (max. 40 A) must be protected with external fuse
1	L Heater	
2	not connected	
3	not connected	
4	N Heater	
11	Sensor RTD; Sensor TC +	
12	Sensor RTD; Sensor TC -	
PE	Protective earth connection	

## 11 Repair and maintenance

If the controller is damaged, please return the controller to us with an error description.

Maintenance intervals and maintenance directives according to DGVU Rule 3 apply.

If the device is dirty, turn power off, and clean it with a damp cloth. Heavy dirt may be cleaned with a non-abrasive, solvent-free cleaning agent.

## 12 Disassembly and disposal



The device may only be disassembled when it is switched off, disconnected from the mains and secured!



Electronic devices are recyclables and do not belong in the household waste! Dispose of the product at the end of its service life in accordance with applicable legislation.



### 13 Drilling template



Important: Leave at least 300 mm / 12 inch at the top and 50 mm / 2 inch of free space around the controller for easy cover opening and air ventilation.

Check the scale after printing for correct size, for correct drilling positions.

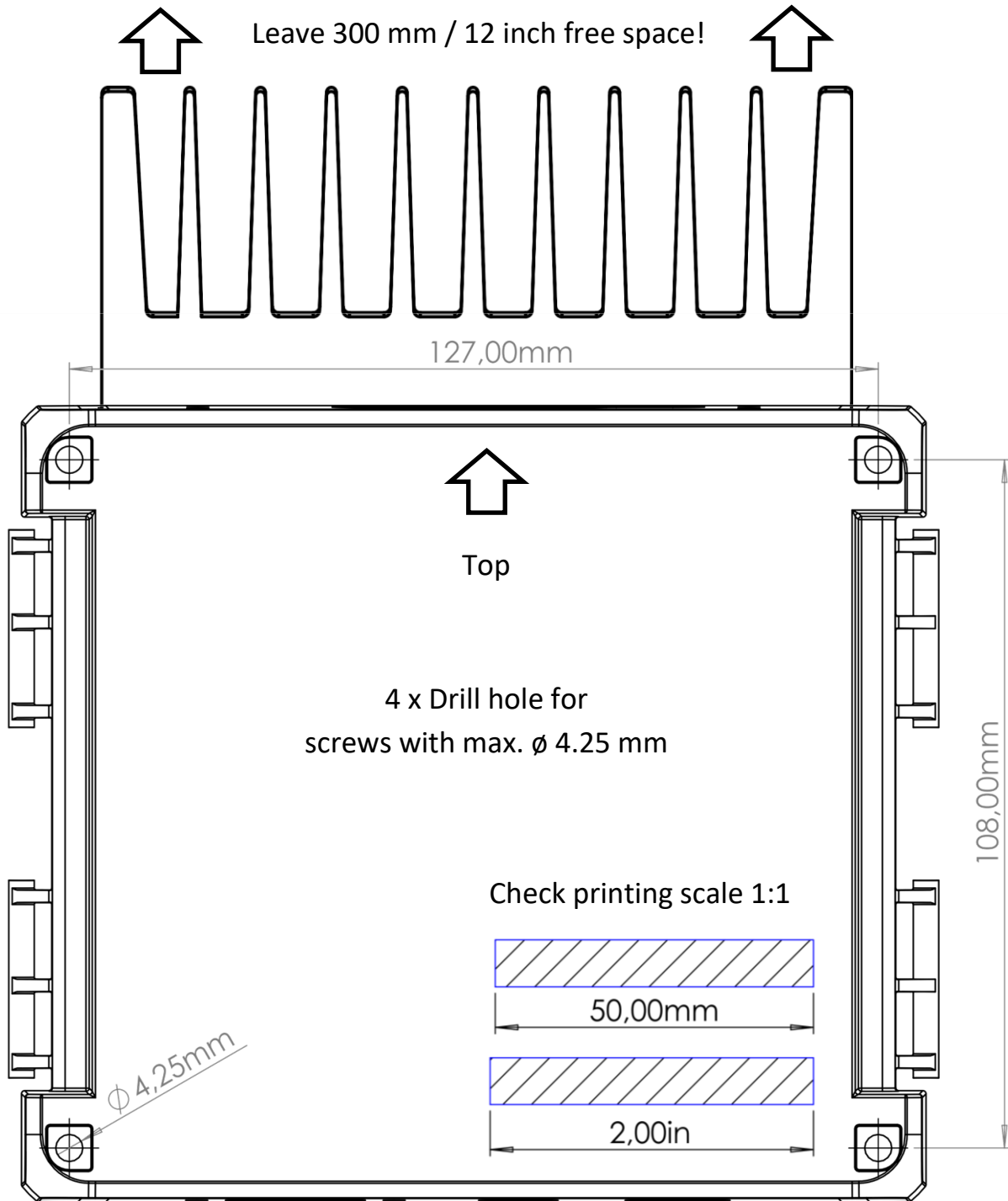

## 14 EU-Declaration of conformity

### EU-DECLARATION OF CONFORMITY

winkler.eu



Manufacturer: Winkler AG  
Englerstr. 24  
69126 Heidelberg

Contact: Tel.: +49 6221 3646-0  
Fax.: +49 6221 3646-40  
[sales@winkler.eu](mailto:sales@winkler.eu)  
[www.winkler.eu](http://www.winkler.eu)

Product group: Temperature controllers

Series / item: **Series W-600 / WRW6...**

Directives: Directive 2014/35/EU Low Voltage Directive  
Directive 2014/30/EU Electromagnetic Compatibility  
Directive 2011/65/EU restriction of the use of certain hazardous  
substances in electrical and electronic  
equipment  
Directive 2017/2102/EU amending Directive 2011/65/EU

We hereby declare that in planning and manufacturing of this product the basic safety and health requirements of the EU Directives mentioned above have been observed.

Further rules and technical specifications applied:

EMC requirements: EN 61326-1:2013  
Emission: EN 61000-6-4:2011  
Immunity: EN 61000-6-2:2006  
Safety requirements: EN 61010-1:2011

Any modification to the product without our consent will make this declaration invalid.

Heidelberg, April 17<sup>th</sup>, 2019

Winkler AG

A blue ink signature of CEO A. Zenner, consisting of a stylized, flowing line that starts with a large 'Z' and ends with a horizontal line.

CEO A. Zenner